

# Huba Control

Huba Control AG – Headquarters Schweiz  
Industriestrasse 17, 5436 Würenlos  
Telefon +41 (0) 56 436 82 00  
Telefax +41 (0) 56 436 82 82  
info.ch@hubacontrol.com

Huba Control AG – Niederlassung Deutschland  
Schlattgrabenstrasse 24, 72141 Walddorfhäslach  
Telefon +49 (0) 7127 23 93 00  
Telefax +49 (0) 7127 23 93 20  
info.de@hubacontrol.com

Huba Control SA – Succursale France  
Rue Lavoisier, Technopôle Forbach-Sud  
57602 Forbach Cedex  
Téléphone +33 (0) 387 847 300  
Télécopieur +33 (0) 387 847 301  
info.fr@hubacontrol.com

Huba Control AG – Vestiging Nederland  
Hamseweg 20A, 3828 AD Hoogland  
Telefoon +31 (0) 33 433 03 66  
Telefax +31 (0) 33 433 03 77  
info.nl@hubacontrol.com

Huba Control AG – Branch Office United Kingdom  
Unit 3 Network Point, Range Road  
Witney Oxfordshire OX29 0YD  
Phone +44 (0) 1993 776 667  
Fax +44 (0) 1993 776 671  
info.uk@hubacontrol.com

Huba Control AG – Rep. Office China  
CBC Building, 49A Wuyi Road  
Shanghai 200050  
Phone +86 (0) 21 511 808 21  
Fax +86 (0) 21 515 520 99  
info.cn@hubacontrol.com

699

Relativ-, Vakuum- und Differenzdrucktransmitter  
*Bedienungsanleitung (Seite 2-7)*

Relative, vacuum and differential pressure transmitter  
*Operating instructions (page 8-13)*

Transmetteur de pression relative, dépression  
et pression différentielle  
*Mode d'emploi (page 14-19)*

# Huba Control



CE



## Before operating refer to the instruction manual!

Any person entrusted with the set-up or operation of the device, must have read and understood this operation manual, in particular all safety notes. The guarantee is invalid in respect of damage resulting from a failure to follow the instructions, incorrect handling or inappropriate use. We accept no responsibility for consequential damages resulting from any of the above.

## Safety information



### General information

In order to ensure safe operation, the device may only be operated in accordance to the specifications stated in this operation manual. Furthermore, all legal and safety regulations concerning this specific application should be observed. This also applies to the use of accessories.

### Correct use to the intended purpose

These devices are designed for indication and monitoring of process variables. All other forms of usage do not comply with the intended purpose. These sensors may not be used solely as means for prevention of dangerous machine and system conditions. Machines and systems must be constructed in such a way, that faulty states cannot lead to a dangerous situation for the operating staff (e.g. due to independent limit switches, mechanical interlocking devices, etc.).

### Qualified staff

The devices may only be installed, connected, set-up and operated by qualified staff and in compliance with the technical specifications. Qualified staff is defined as persons, who are familiar with set-up, mounting, start-up and operation of this device and who possess a recognized degree or certificate of appropriate professional training.

### Remaining hazards

These sensors employ state-of-the-art technology and are safe to operate. However, if they are installed and operated by unqualified staff, an element of risk remains.



In this manual the remaining risks are marked by the following symbol:  
This symbol is posted where there is a risk of serious injury or death or the damage of material and property, if the warning is ignored

## Installation and set-up instructions

Even though the device is excellently protected against electro-magnetic interference, installation and cabling must be carried out correctly to ensure interference immunity.

1. Use shielded cables for the signal and control lines with the connecting lead of the screen being kept as short as possible. The connection point of the shielding depends on the existing connection conditions.
2. Never route signal and control cables together with the trunk line or feeder cables of motors, cylinder coils, rectifiers etc. The cables must be routed in conductive and grounded cable conduits. This applies especially to long-distance cables, or environments in which the cables are exposed to strong radio waves from broad casting stations.
3. Signal lines should be installed in mounting cabinets and as far away as possible from contactors, control relays, transformers and other sources of interference.
4. Fix plug screw only with closed cover



## Mounting

- Prior to mounting or removing the sensor it must be verified that the system is depressurized.
- Do not mount sensors in locations subject to high pressure pulses.
- Significant thermal changes in the sensor environment can lead to a zero shift. As a result, the measuring value displayed in a depressurized state will not read zero. This kind of drift can be corrected by zero point reset.
- Supply from SELV or class 2 source limited energy circuit 15 W or less
- Use Copper conductors only

## Further information

Voltage version 0 ... 5, 0 ... 10V

Please consider a possible fall of voltage in the GND supply especially in connection with the use of the display and display lighting. Recommended is a short cable with a large crosssection.

## Installation arrangement

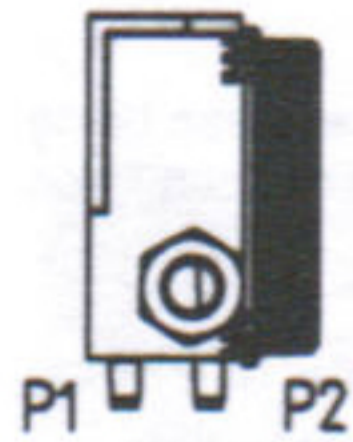

**Recommended installation arrangement:**  
vertical, with pressure connections facing downward,  
drain of possible condensed water (factory calibration).

Notice: Mount the transmitter with minimum 10 mm distance to magnetic material. If this is not possible there is a failure of up to minus 1 Pa for transmitters mounted on sheet steel. bis minus 1 Pa entstehen.

### ZP = Push Zero point reset.

The installation position is variable by using the zero point reset button. Pressure variations are resettable after installation.

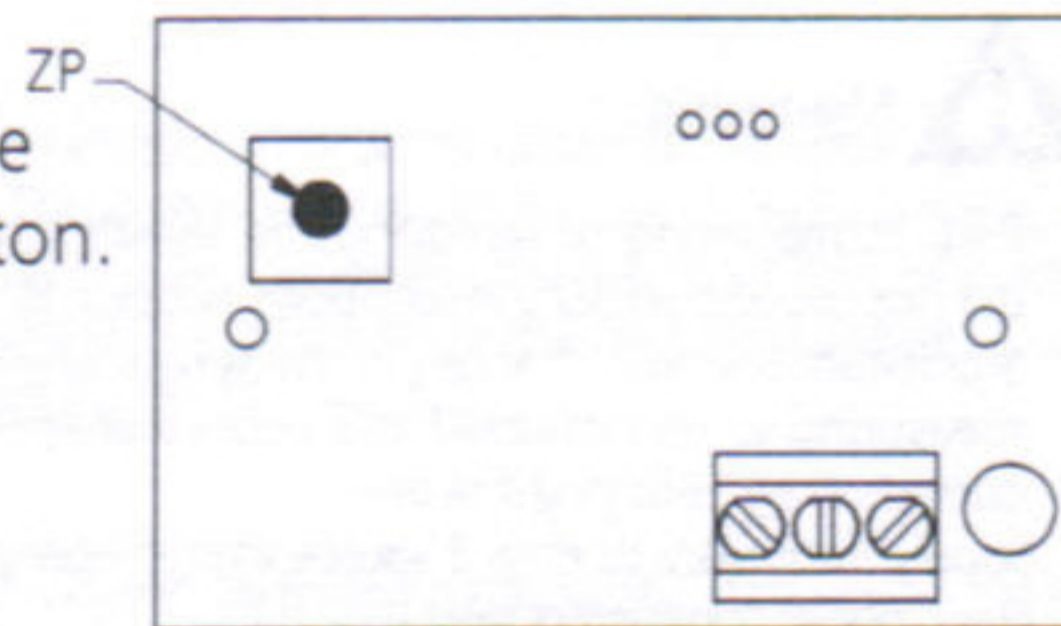

Ensure the power supply is not interrupted when storing customer settings (NB – reset,).

## Connection diagrams

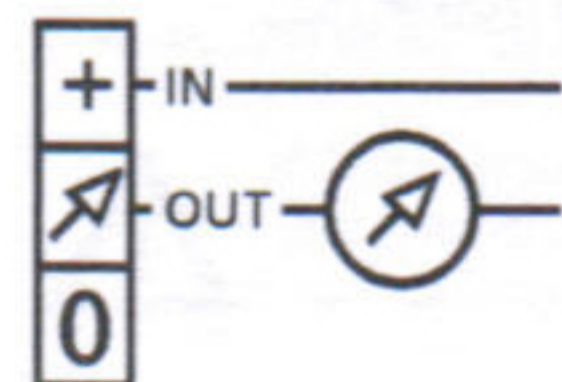

2 wire

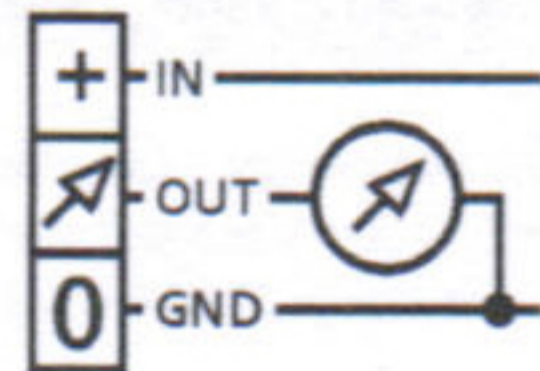

3 wire

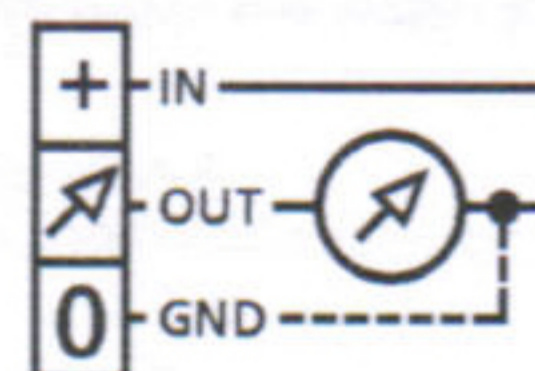

Universal  
2 and 3 wire

## Version with measurement configuration only

(Adjustability 1)

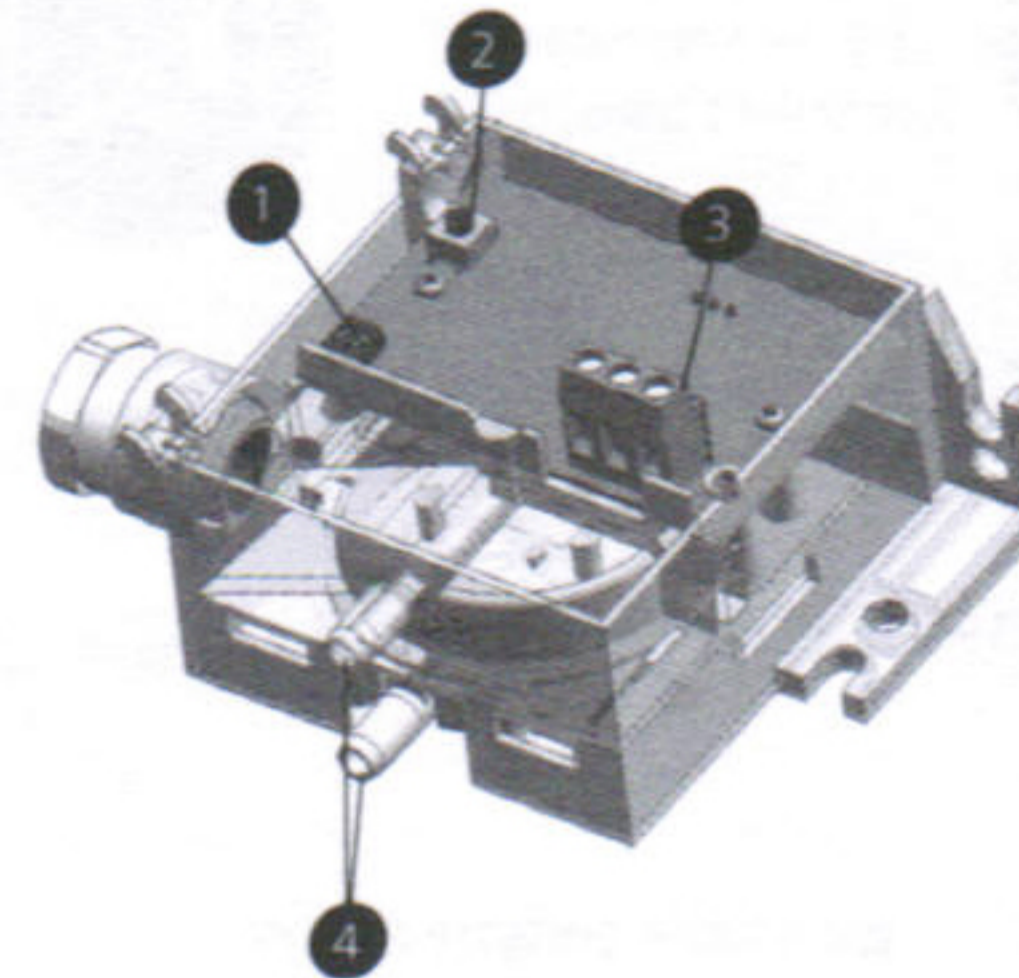

1. DIP-Switch (dual)
2. Zero point reset
3. Connecting terminal
4. Pressure connector P1 and P2

### Pressure range <sup>1)</sup>

	0	1
Range00	0	0
Range01	0	1
Range10	1	0
customer adjustment <sup>2)</sup>	1	1

<sup>1)</sup> Pressure range

<sup>2)</sup> Customized factory adjustment

<sup>3)</sup> DIP-Switch position according to factory adjustment (see cover inside)

## Adjustable pressure ranges

**Factory Settings**

		1	2
<b>Pressure range<sup>1)</sup></b>	Range00	0	0
	Range01	0	1
	Range10	1	0

<sup>1)</sup> Pressure ranges

<sup>2)</sup> DIP-Switch position according to factory adjustment (see cover inside)

### DIP-Switch position

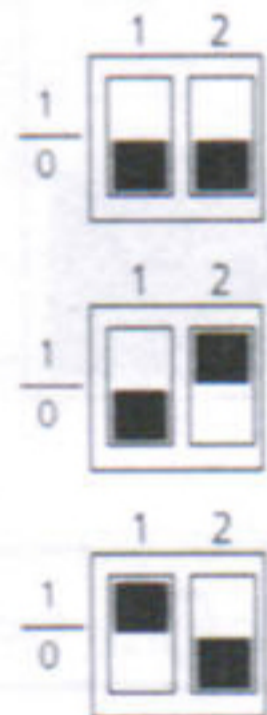

### switchable pressure ranges

Range 00 (in mbar)	0.5	1	3	5	10	16	25	50
Range 01 (in mbar)	0.3	0.5	1	3	5	10	16	25
Range 10 (in mbar)	0.3	0.3	0.5	1	3	5	10	16

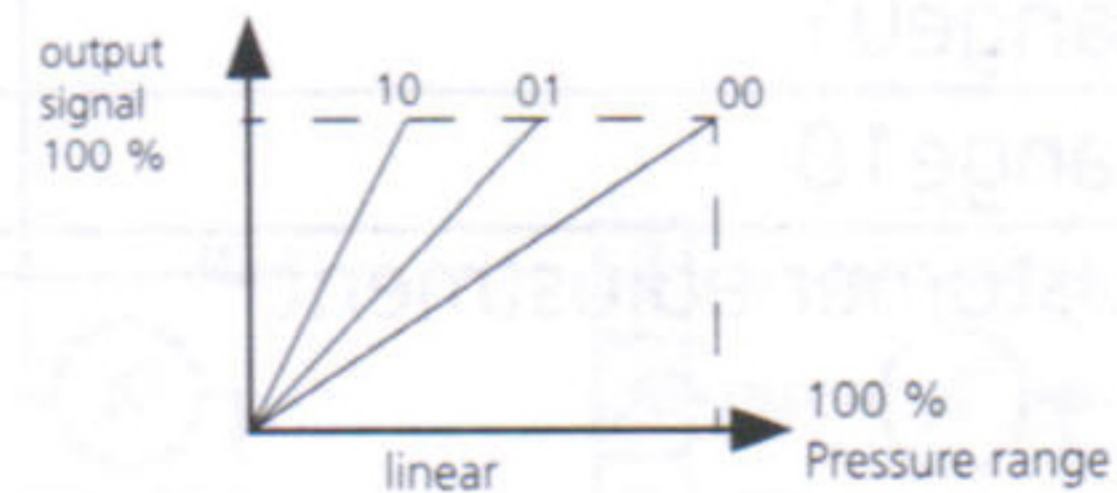

The factory setting information (pressure range and article no.) is located on the specification label. Because of customer configuration the settings can differ from this information and before the device is configured please refer to the operating manual.

**Electromagnetic compatibility**

**CE conformity according EN 61326-2-3.**